



United Pacific

HIGH POWER LED HEADLIGHT

Item # 31144, 31145, 31146, 31147

Connect Plug A & B to Original OE Wire Harness

- A**
- ① Turn signal / LED light bar
 - ② Low beam
 - ③ High beam
- B** Back cover turn signal

Lower Adjuster:

Clockwise = Beam UP
Counterclockwise = Beam DOWN

Upper Adjuster:

Clockwise = Beam RIGHT
Counterclockwise = Beam LEFT

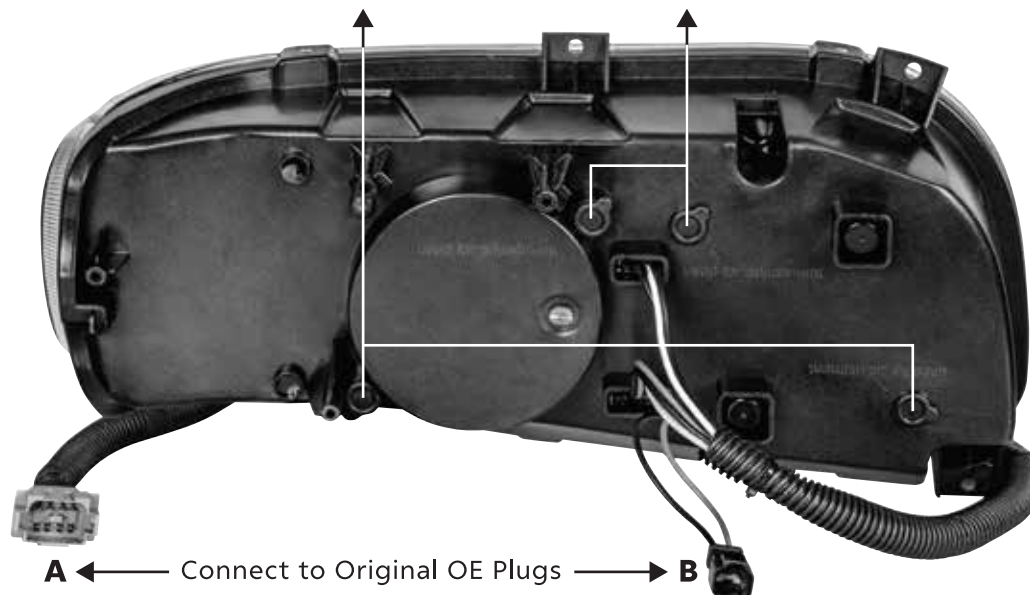

Normal Fogging / Condensation

This bulletin provides information regarding headlights that may experience fogging or condensation inside of the headlamp assembly. A drop in air temperature may cause condensation to form on the inside of a cool headlamp lens. Generally, fogging is considered normal and can be eliminated by turning on the headlamp with the engine running for several minutes. In most cases, operating the vehicle in normal driving condition will clear the headlamp fogging. Headlamp assembly replacement **WILL NOT** be necessary in most cases.

Note

- If any of the following conditions occur, please consult with a professional mechanic to determine the water source:
 1. If condensation/fogging fails to dissipate after operating the headlight with the engine running for 30 minutes
 2. If water pooled inside the headlamp
- A high pressure washer may also cause water to be forced into the headlamp assembly.

2

1

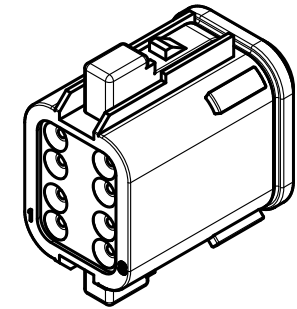

SCALE 1:1

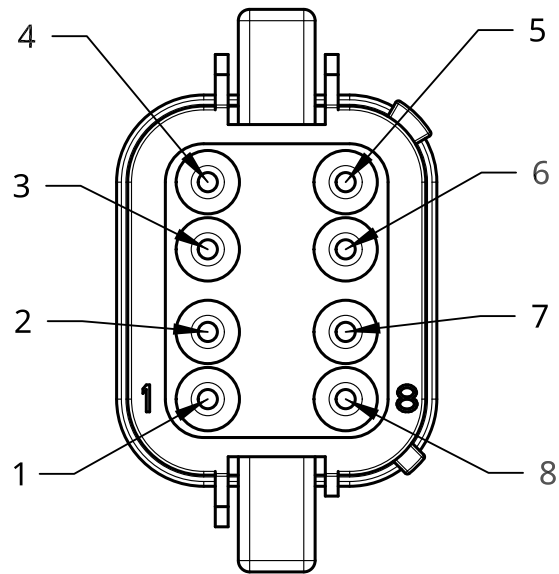

Pin #	WIRE FUNCTION
1	Ground (-)
2	*Rear Housing LED (+)
3	Ground (-)
4	High Beam (+)
5	Low Beam (+)
6	Ground (-)
7	Turn Signal (+)
8	Parking / Position Light (If Equipped) (+)

NOTE: VIEW FROM BACK OF VEHICLE'S EXISTING HEADLIGHT WIRING HARNESS MALE CONNECTOR

*Rear Housing LED Plug

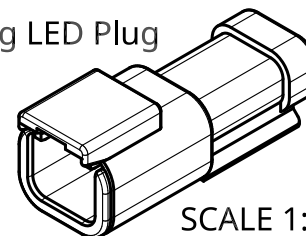

SCALE 1:1

TITLE			
Peterbilt 388/389 Headlight Connector Pinout			
SIZE	DWG NO.	REV.	
A	05082020		
SCALE	WEIGHT	SHEET	
2:1		1 of 1	

2

1

B

A

B

A